

# Threading Inserts Parting & Grooving Inserts

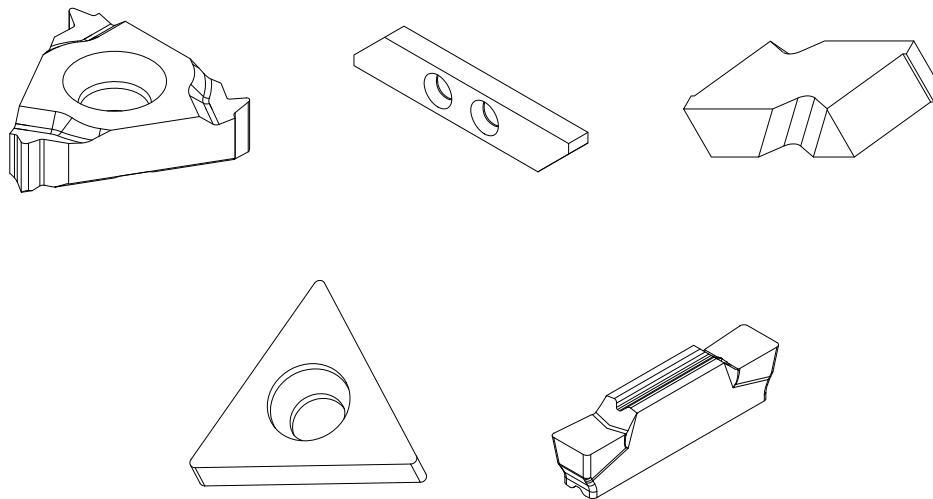

Turning  
Inserts



Threading  
Inserts  
Parting &  
Grooving  
Inserts



Milling  
Inserts



Woodworking  
Inserts



Drilling  
Inserts



Circular  
Saw



Carbide  
Flats

# Threading Inserts

## Parting & Grooving Inserts

### Threading Inserts

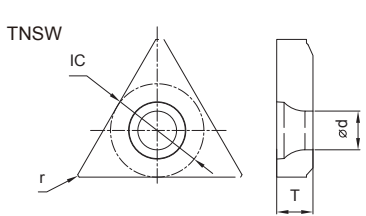
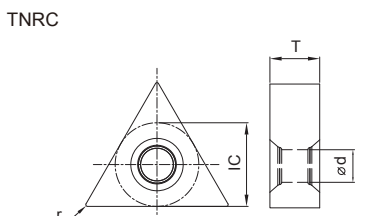
| Shape  | Style      | Dimension (mm) |      |      |     | GEHM Grade |      |
|--|------------|----------------|------|------|-----|------------|------|
|  |            | IC             | T    | d    | r   | GU20       | GM15 |
|  <p>TNSW</p>  | TNSW110304 | 6.35           | 3.18 | 3.00 | 0.4 | •          | •    |
|  | TNSW160304 | 9.525          | 3.18 | 4.00 | 0.4 | •          | •    |
|  | TNSW220408 | 12.70          | 4.76 | 4.85 | 0.8 | •          | •    |
|  <p>TNRC</p> | TNRC160302 | 9.525          | 3.18 | 3.89 | 0.2 | •          |      |
|  | TNRC160402 | 9.525          | 4.76 | 3.89 | 0.2 | •          |      |
|  | TNRC220402 | 12.70          | 4.76 | 5.16 | 0.2 | •          |      |
|  | TNRC270602 | 15.875         | 6.35 | 6.40 | 0.2 | •          |      |

### Threading Chaser

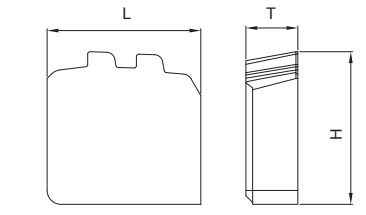
| Shape   | Style    | Dimension (mm) |       |       |      | GEHM Grade |
|---|----------|----------------|-------|-------|------|------------|
|   |          | Teeth          | L     | H     | T    | GP10       |
|  | BC5B11-2 | 2              | 16.26 | 16.15 | 5.49 | •          |
|   | C8E1-3   | 3              | 16.26 | 15.67 | 5.59 | •          |
|   | C5BE1-3  | 3              | 17.22 | 15.08 | 5.44 | •          |
|   | C5BE2-3  | 3              | 17.22 | 15.33 | 5.44 | •          |
|   | C5BE1-4  | 3              | 17.22 | 15.44 | 5.44 | •          |
|   | C8I1-4   | 4              | 16.26 | 16.64 | 5.59 | •          |
|   | P5B11-5  | 5              | 25.78 | 16.26 | 5.59 | •          |
|   | C8I1-7   | 7              | 25.91 | 16.51 | 5.59 | •          |

## Parting & grooving Inserts

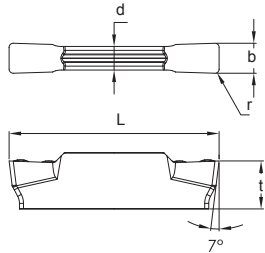
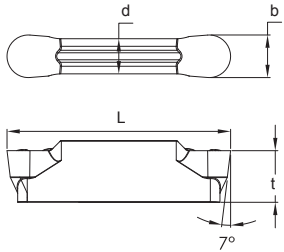
| Shape   | Style   | Dimension (mm) |       |      |     | GEHM Grade |
|---|---------|----------------|-------|------|-----|------------|
|   |         | b              | L     | d    | r   | GM15       |
|   | MGMM150 | 1.50           | 16.00 | 1.20 | 0.2 | •          |
|   | MGMM200 | 2.00           | 16.00 | 1.60 | 0.2 | •          |
|   | MGMM250 | 2.50           | 18.50 | 2.00 | 0.2 | •          |
|   | MGMM300 | 3.00           | 21.00 | 2.35 | 0.4 | •          |
|   | MGMM400 | 4.00           | 21.00 | 3.30 | 0.4 | •          |
|   | MGMM500 | 5.00           | 26.00 | 4.10 | 0.8 | •          |
|   | MGMM600 | 6.00           | 26.00 | 5.00 | 0.8 | •          |
|  | MRMM200 | 2.00           | 16.00 | 1.65 | 1.0 | •          |
|   | MRMM300 | 3.00           | 21.00 | 2.35 | 1.5 | •          |
|   | MRMM400 | 4.00           | 21.00 | 3.30 | 2.0 | •          |
|   | MRMM500 | 5.00           | 26.00 | 4.10 | 2.5 | •          |
|   | MRMM600 | 6.00           | 26.00 | 5.00 | 2.5 | •          |

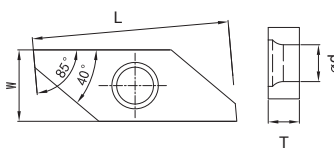
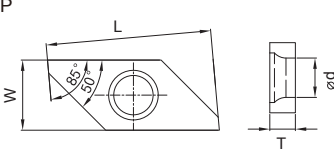
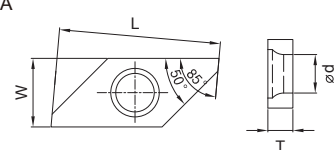
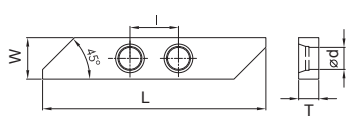

## Parting & grooving Inserts

| Shape  | Style    | Dimension (mm) |      |      |      | GEHM Grade |
|--|----------|----------------|------|------|------|------------|
|  |          | L              | W    | T    | d    | GU25UF     |
|  <p>GKF</p>   | GKF12R   | 21.20          | 9.00 | 3.25 | 5.00 | •          |
|  | GKF12L   | 21.20          | 9.00 | 3.25 | 5.00 | •          |
|  | GKF16R   | 27.00          | 9.80 | 4.25 | 5.00 | •          |
|  | GKF16L   | 27.00          | 9.80 | 4.25 | 5.00 | •          |
|  <p>GCP</p> | GCP12R   | 19.70          | 8.30 | 2.75 | 4.48 | •          |
|  | GCP12L   | 19.70          | 8.30 | 2.75 | 4.48 | •          |
|  <p>GCA</p> | GCA16R   | 24.40          | 9.70 | 3.75 | 4.68 | •          |
|  | GCA16L   | 24.40          | 9.70 | 3.75 | 4.68 | •          |
|  <p>GF</p>  | GF038001 | 38.50          | 8.40 | 4.00 | 4.60 | •          |
|  | GF043001 | 43.50          | 8.40 | 4.80 | 4.30 | •          |



Turning Inserts



Threading Inserts  
Parting & Grooving Inserts



Milling Inserts



Woodworking Inserts



Drilling Inserts



Circular Saw



Carbide Flats

## Parting&grooving Inserts

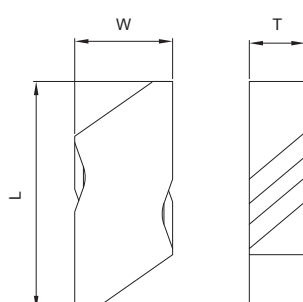
| Shape  | Style     | Dimension (mm) |       |       | GEHM Grade |      |       |
|--|-----------|----------------|-------|-------|------------|------|-------|
|  |           | L              | W     | T     | GU10       | GU20 | GT20A |
|  | KNMR1104R | 14.43          | 5.94  | 4.19  | •          |      | •     |
|  | KNMR1104L | 14.43          | 5.94  | 4.19  | •          |      | •     |
|  | KNMR2005R | 24.26          | 9.19  | 5.33  | •          | •    | •     |
|  | KNMR2005L | 24.26          | 9.19  | 5.33  | •          | •    | •     |
|  | KNMR2406R | 29.90          | 12.01 | 6.93  | •          | •    | •     |
|  | KNMR2406L | 29.88          | 12.01 | 6.93  | •          | •    | •     |
|  | KNMR2410R | 29.78          | 12.01 | 10.16 | •          |      | •     |
|  | KNMR2410L | 29.78          | 12.01 | 10.16 | •          | •    | •     |
|  | KNMR3510R | 41.61          | 17.86 | 10.16 | •          | •    | •     |
|  | KNMR3510L | 41.61          | 17.86 | 10.16 | •          | •    | •     |
|  | KNMR3513R | 41.61          | 17.86 | 13.00 |            | •    | •     |
|  | KNMR3513L | 41.61          | 17.86 | 13.00 |            |      |       |



Turning Inserts



Threading Inserts  
Parting &  
Grooving  
Inserts



Milling  
Inserts



Woodworking  
Inserts



Drilling  
Inserts



Circular  
Saw



Carbide  
Flats